

C.I.P.

256 Win. Mag.

Country of Origin: US

TAB. II

Date 84-06-14

Revision 02-05-15

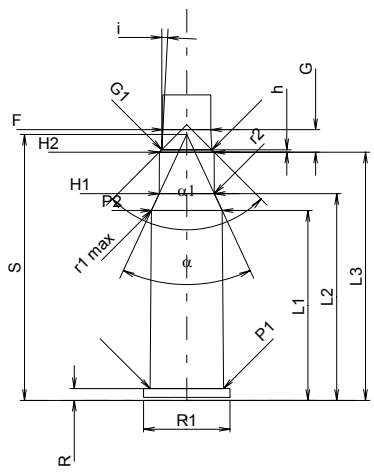
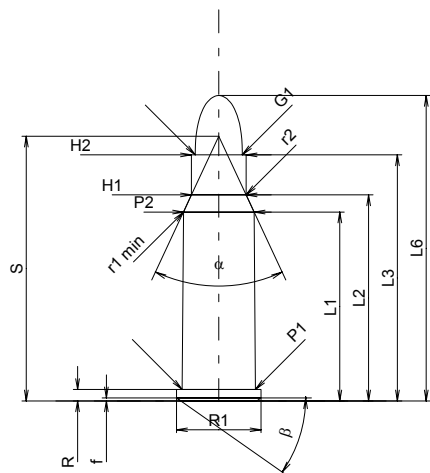

CARTRIDGE MAXI

Lengths

L1	=	24.98
L2	=	27.25
L3 ¹⁾	=	32.54
L4	=	
L5	=	
L6	=	40.39

Case Head

R ¹⁾	=	1.52	-0.25
R1	=	11.18	
R3	=		
E	=		
E1	=		
e min	=		
delta	=		
f	=	0.40	
beta	=	35°	

Powder Chamber

P1	=	9.68
P2 *	=	9.35

Junction Cone

alpha *	=	50°
S *	=	35.01
r1 min	=	0.76
r2	=	2.54

Collar

H1 *	=	7.24
H2 ¹⁾	=	7.24

Projectile

G1 ¹⁾	=	6.23
G2	=	
F	=	
L3+G ¹⁾	=	35.52

Pressures (Energies)

Method Transducer

Pmax	=	3500 bar
PK	=	4025 bar
PE	=	4375 bar
M	=	17.50
EE	=	1365 Joule

Miscellaneous Dimensions

Fe ¹⁾	=	0.15
delta L	=	

CHAMBER MINI

Lengths

L1	=	25.11
L2	=	27.34
L3 ¹⁾	=	32.82

Breech

R ¹⁾	=	1.55
R1	=	11.43
R2	=	
R3	=	
r	=	

Powder Chamber

E	=	
P1 ¹⁾	=	9.70
P2 *	=	9.37

Junction Cone

alpha *	=	50°
S *	=	35.16
r1 max	=	0.76
r2	=	2.54

Collar

H1 *	=	7.29
H2 ¹⁾	=	7.26

Commencement of Rifling

G1 ¹⁾ *	=	6.63
G ¹⁾	=	2.98
alpha 1 *	=	90°
h	=	0.32
s	=	
i ¹⁾ *	=	3°
w	=	

Barrel

F ¹⁾ *	=	6.35
Z ¹⁾	=	6.50

Grooves

b	=	2.01
N	=	6
u	=	356.00
Q	=	32.59 mm ²

Scale 1:1

Dimensions in << mm >>
Dimensions and Tolerances for Proof Barrels
see Appendix CR 1.

Notes: 1) Check for safety reasons
* Basic dimensions